

19th February 2007
3DMPC
SWITCHES + SENSORS

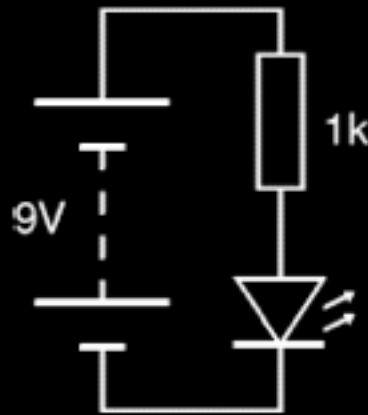



FREITAG[®]

SINCE '93

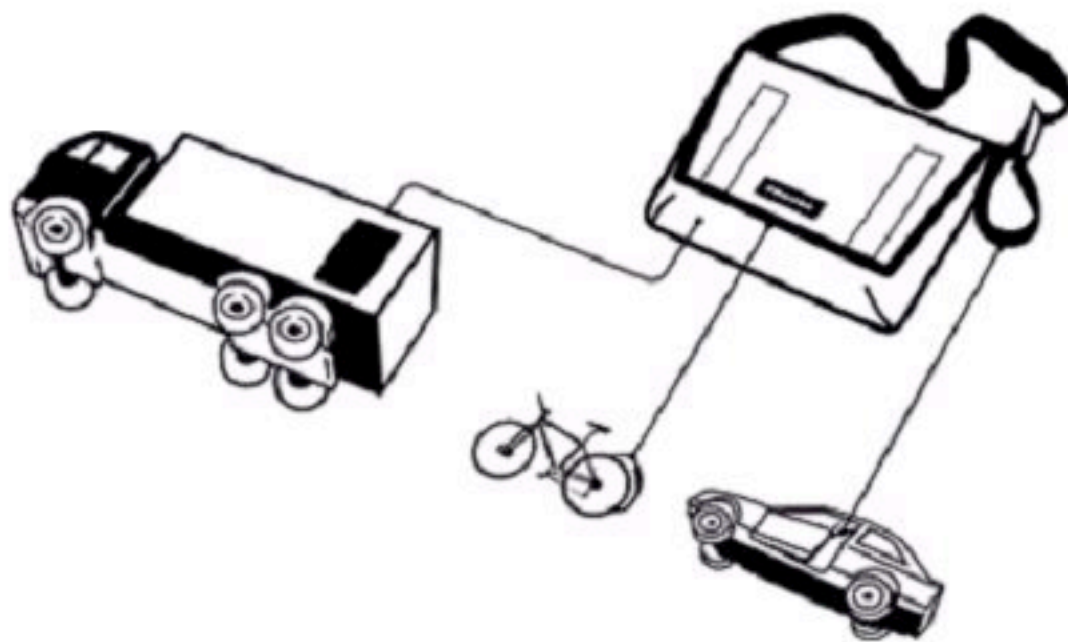









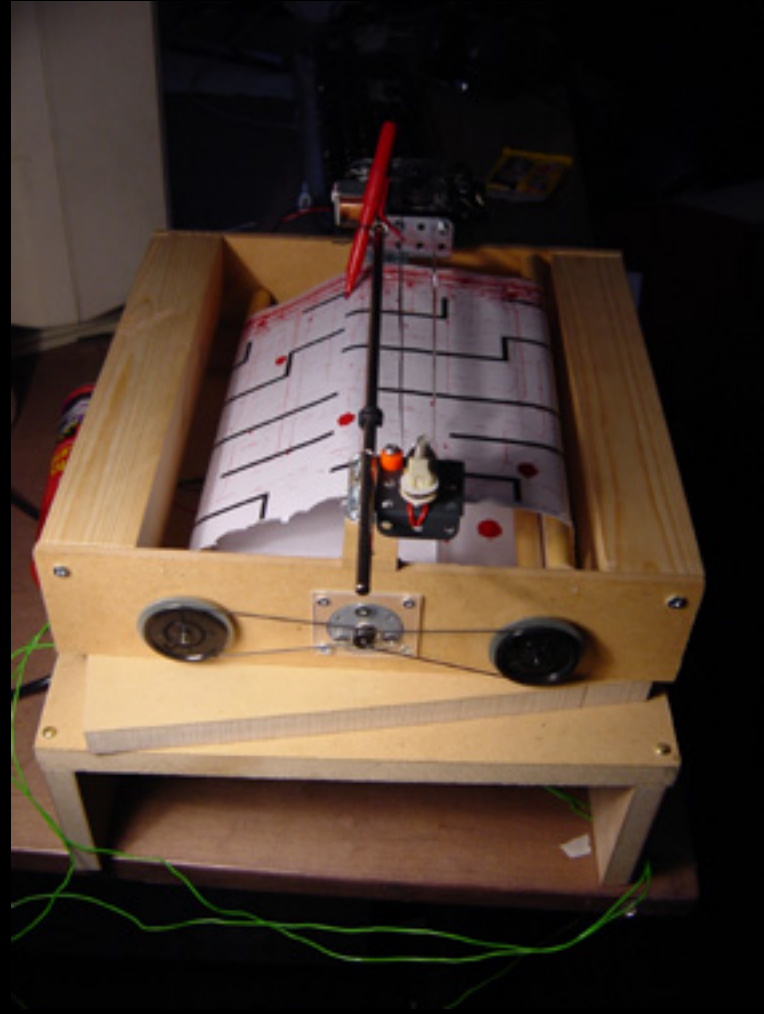

Scheduled Executions

Texas Department of Criminal Justice

Return to Death Row Page

Scheduled Executions

Scheduled Execution	Link	Last Name	First Name	TD CJ Number	Date of Birth	Race	Date Received	County
02/05/2004	Offender Information	Farrish	Scott	99914	02-29-1958	White	02/23/1995	Grimes
02/11/2004	Offender Information	Legone	Edward	99903	03-02-1957	Black	12/01/1993	Tarrant
02-12-2004	Offender Information	Hopkins	Bobby	999101	02-23-1967	Black	09/01/1994	Johnson
02/17/2004	Offender Information	Willingham	Cameron	999041	01-09-1968	White	09/25/1992	Navarro
03/03/2004	Offender Information	Gibson	Marcel	999252	09-29-1974	Black	02/04/1999	Harris
03/04/2004	Offender Information	Harris	Yokelson	999292	11-09-1979	Black	12/25/1999	Dallas
03/30/2004	Offender Information	Capenio	Edward	999165	09-12-1977	Hispanic	02/28/1999	Harris
04-13-2004	Offender Information	Rosales	Michael	999274	01-11-1974	Hispanic	07/16/1999	Lubbock
05-18-2004	Offender Information	Patterson	Kelsey	999005	03-24-1954	Black	07/01/1993	Anderson
06/23/2004	Offender Information	Perez	Ethan	999152	11-19-1979	Hispanic	10/09/94	Harris
06/24/2004	Offender Information	Viviano	Raul	999123	09-29-1975	Hispanic	11/02/1994	Harris

0. How is it determined what date a death row offender will be executed for execution?

Executed Offenders

Texas Department of Criminal Justice

Return to Death Row Page

To search for a specific name or TD CJ number, press CTRL-F on your keyboard.

Executed Offenders

Executive	Link	Last Name	First Name	TD CJ Number	Age	Sex	Race	County	
317	Offender Information	Last Statement	Vickers	Billy	999397	54	01-28-2004	White	Lamar
316	Offender Information	Last Statement	Zimmerman	Kevin	917	42	05-25-2004	White	Jefferson
315	Offender Information	Last Statement	Brice	Kenneth	999203	52	01-14-2004	Black	Collin
314	Offender Information	Last Statement	Matthew	Yhude	999387	27	01-06-2004	Black	Brewer
313	Offender Information	Last Statement	Mayfield	Sean	999	58	12/04/2000	White	Grayson
312	Offender Information	Last Statement	Duncan	Richard	999193	91	12/03/2000	White	Cameron
311	Offender Information	Last Statement	Henry	Robert	999126	41	11-20-2000	White	San Patricio
310	Offender Information	Last Statement	Hayes	Larry	999258	54	05/10/2000	White	Montgomery
309	Offender Information	Last Statement	Jenkins	Allen	684	53	07/24/2000	White	Harris
308	Offender Information	Last Statement	Pearson	Cedric	999296	29	07-23-2000	Black	Tarrant
307	Offender Information	Last Statement	Black, Sr	Christopher	999177	43	07-08-2000	Black	Tell
306	Offender Information	Last Statement	Crawford	Helen	999298	54	07/02/2000	White	Montgomery
305	Offender Information	Last Statement	Johnson	Kia	999138	38	05/11/2000	Black	Brewer
304	Offender Information	Last Statement	Jacobs	Eruck	679	56	05/15/2000	White	Dallas
303	Offender Information	Last Statement	Vaughn	Roger	999209	49	02/06/2000	White	Willbarger
302	Offender Information	Last Statement	Chuang	John	999198	54	08/25/2000	Hispanic	Dallas

Name: Alvin Uriel Goodwin D.R.# 879

DOB: 12 / 27 / 63 Received: 8 / 7 / 87 Age: 23 (when rec'd)

County: Montgomery Date of Offense: 11 / 30 / 86

Age at time of offense: 22 Race: white Height: 5-4

Weight: 190 Eyes: Blue Hair: Brown

Native County: Bula State: Ohio

Prior Occupation: press operator/carpenter Education level: 10 years (GED)

Prior prison record:
#340025, received 8-3-82 from Harris Co. with 5-year sentence for burglary of a motor vehicle and auto theft, paroled to Galveston Co. on 6-24-83. Returned 3-21-85 as a parole violator with a new 2-year sentence for burglary of a motor vehicle from Walker Co. Released under mandatory supervision to Nueces County on 5-13-86.

Summary: Convicted in the November 1986 abduction and shooting death of 20-year-old James Douglas Tillerson of Conroe. Goodwin and accomplice Billy Dan Aitkens Jr. forced their way into Tillerson's mobile home and took a VCR, some video tapes, and a small amount of money while holding a gun on the victim. They then forced Tillerson into Aitkens' car and drove him to a wooded area in the Texaba subdivision near Fawnmist Rd, where he was shot in the arm and head with a .357 caliber pistol. His decomposing body was found there on Jan. 17, 1987. Goodwin and Aitkens were arrested in Burlington, Iowa and returned to Texas on 4-21-87.

Co-Defendants: Billy Dan Aitkens Jr., #455320, W/M, DOB: 11-9-65. Received 6-29-87 from Montgomery Co. with life sentence for murder with a deadly weapon. Assigned to the Clemens Unit.

Race of Victim(s): white male



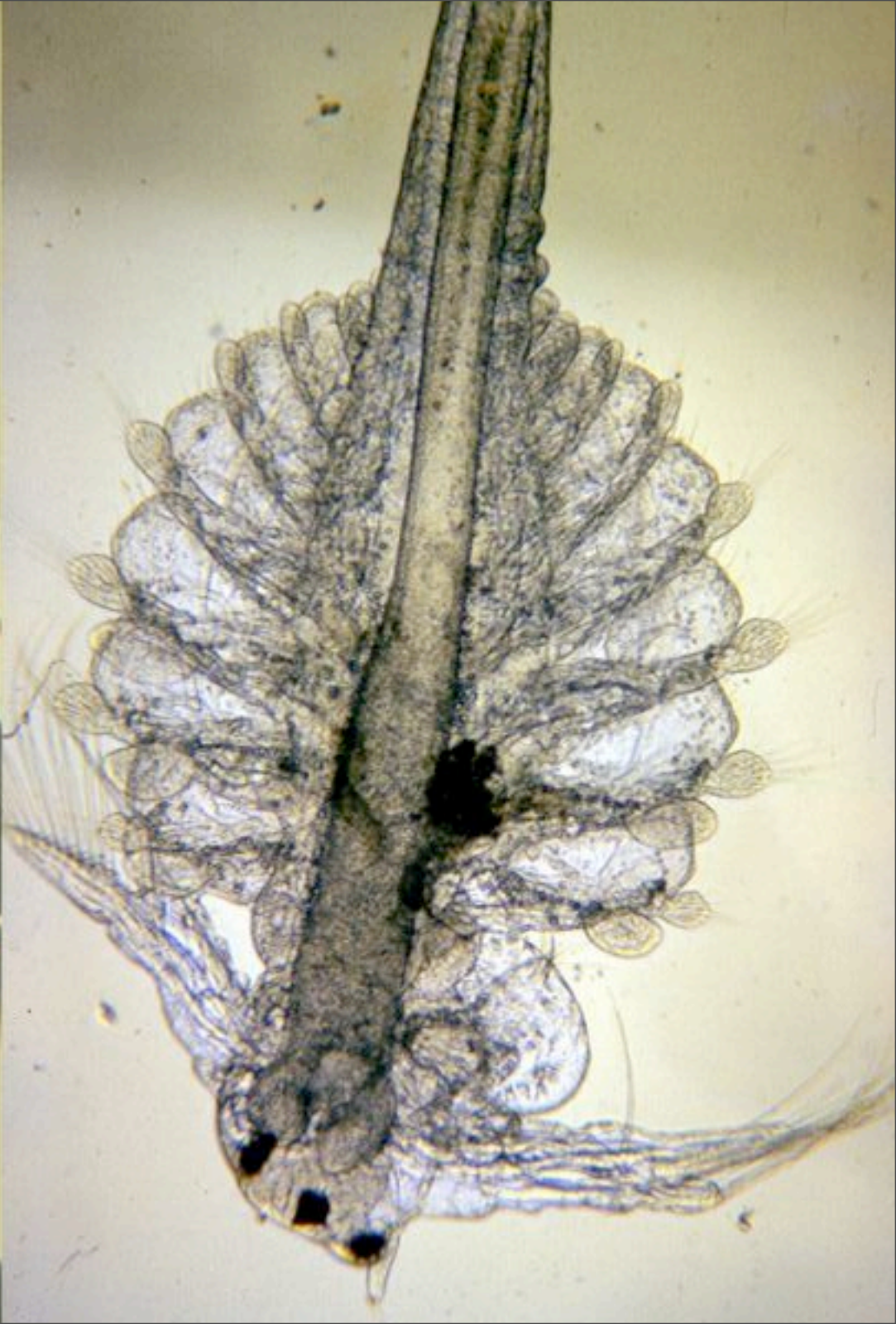
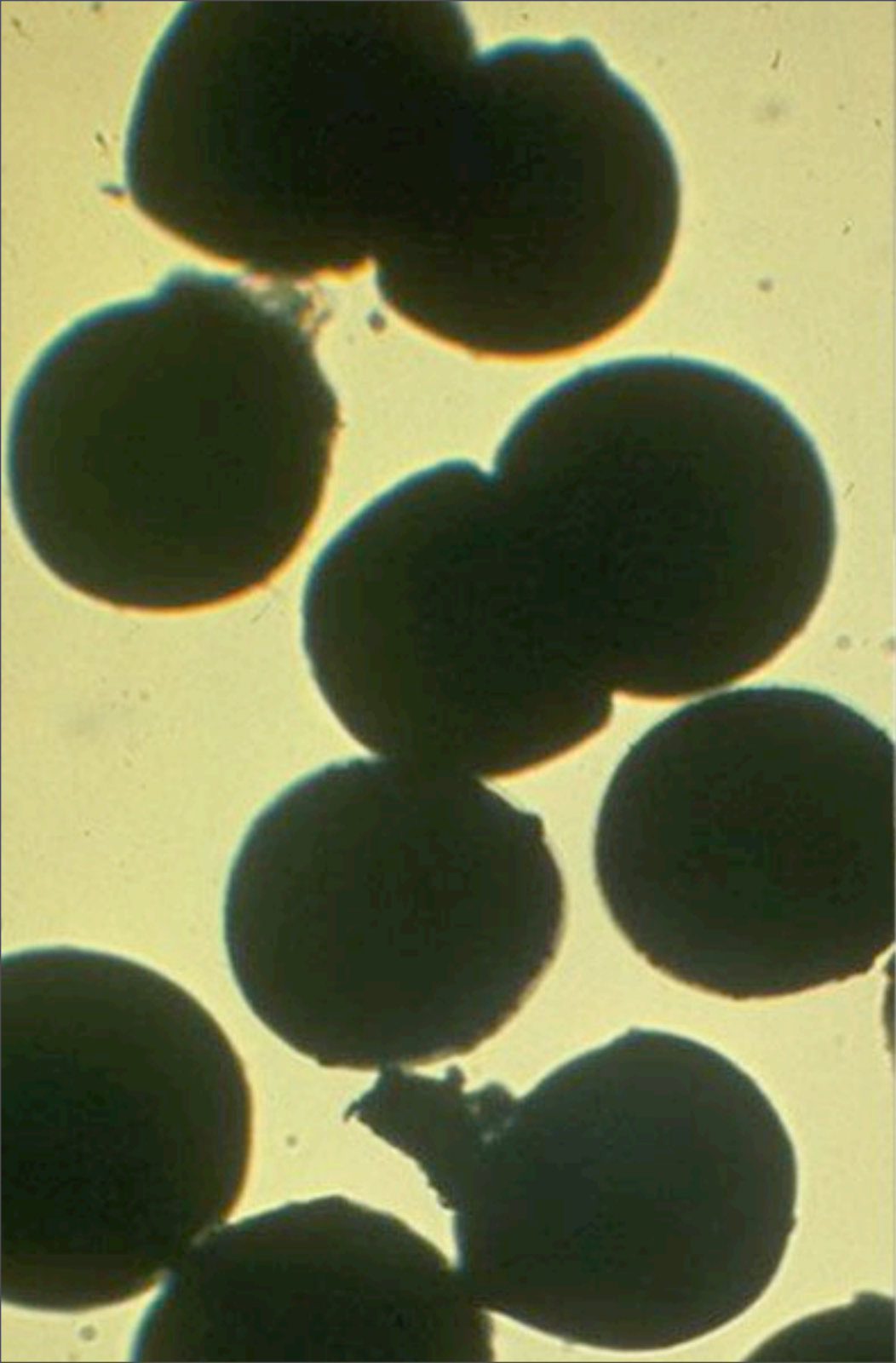

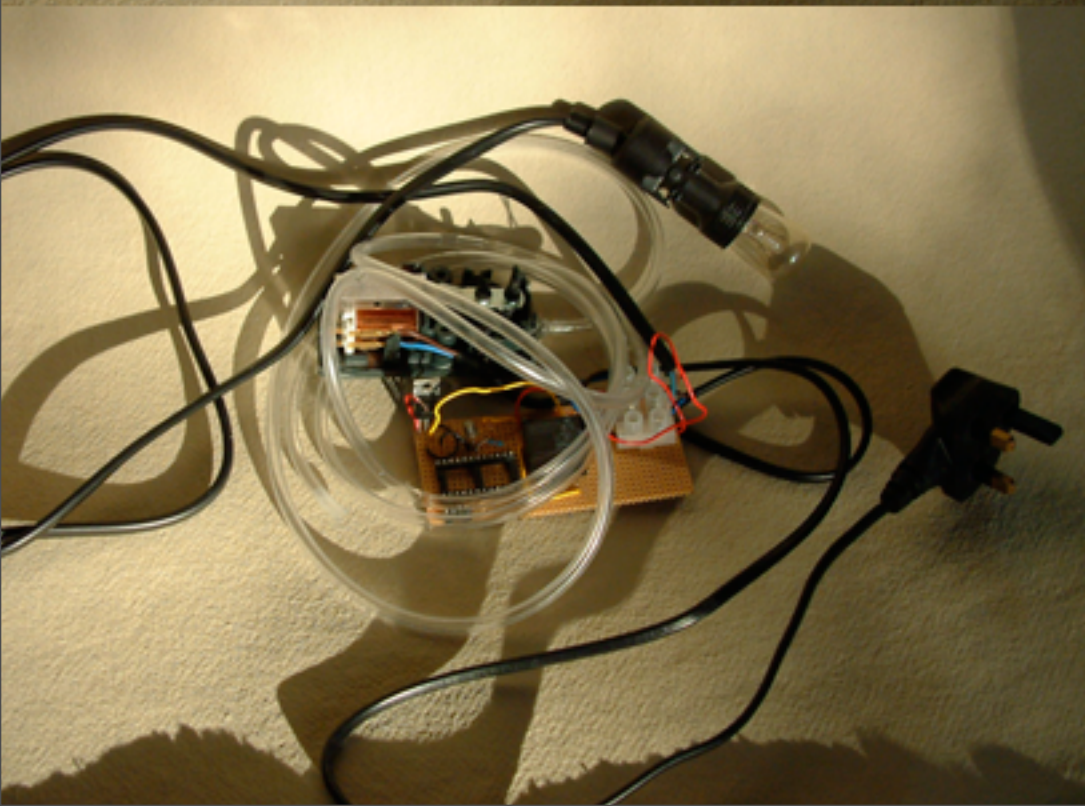
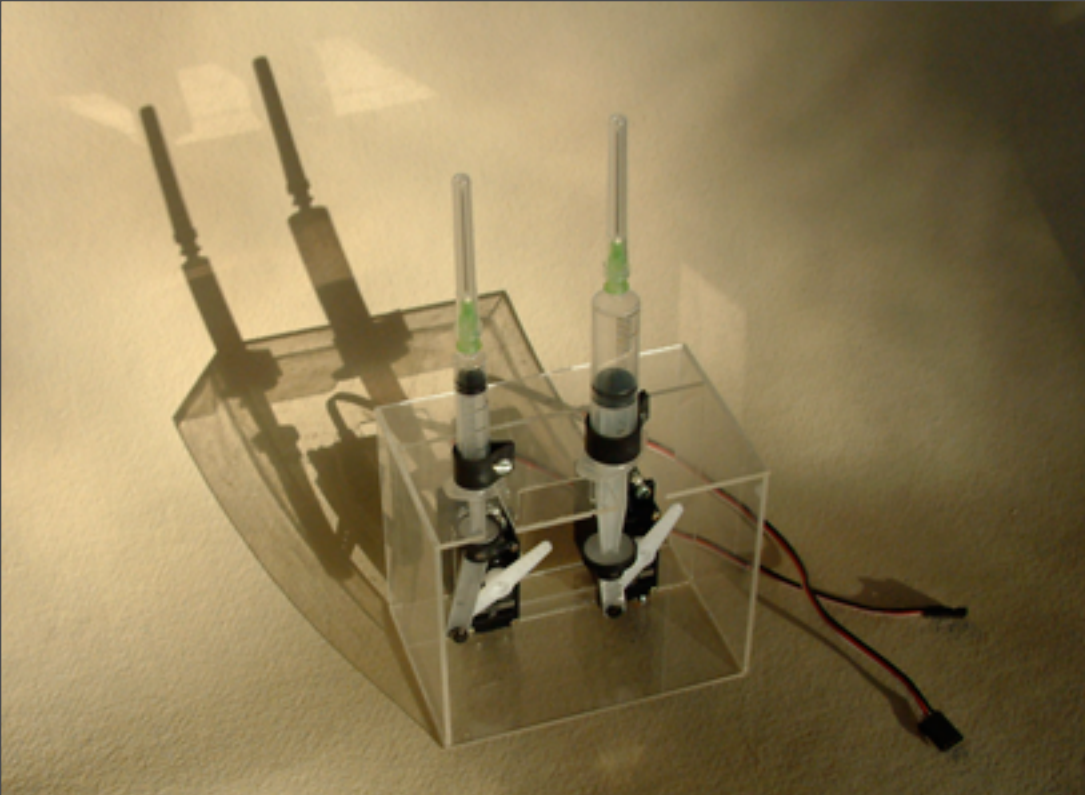





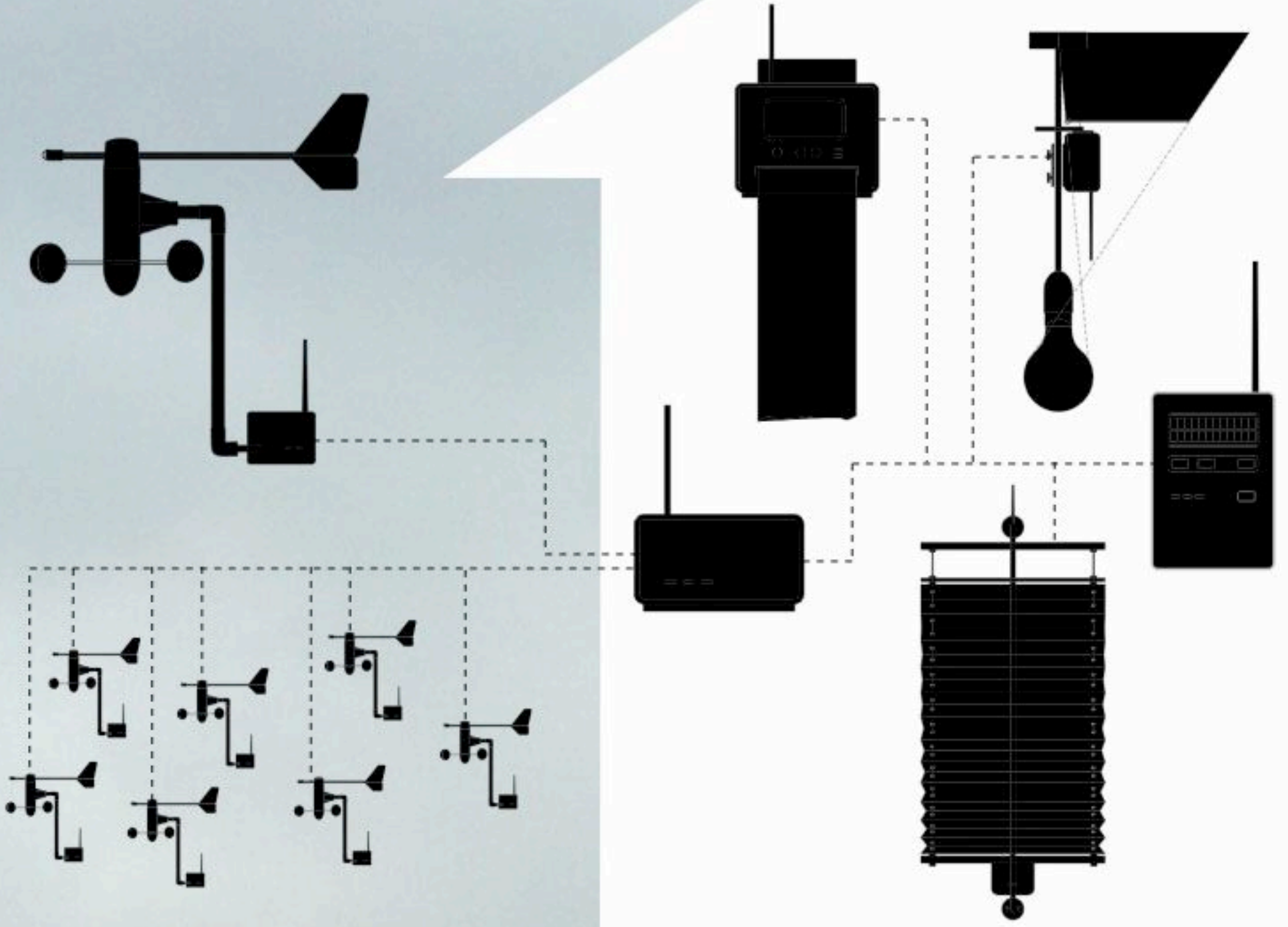



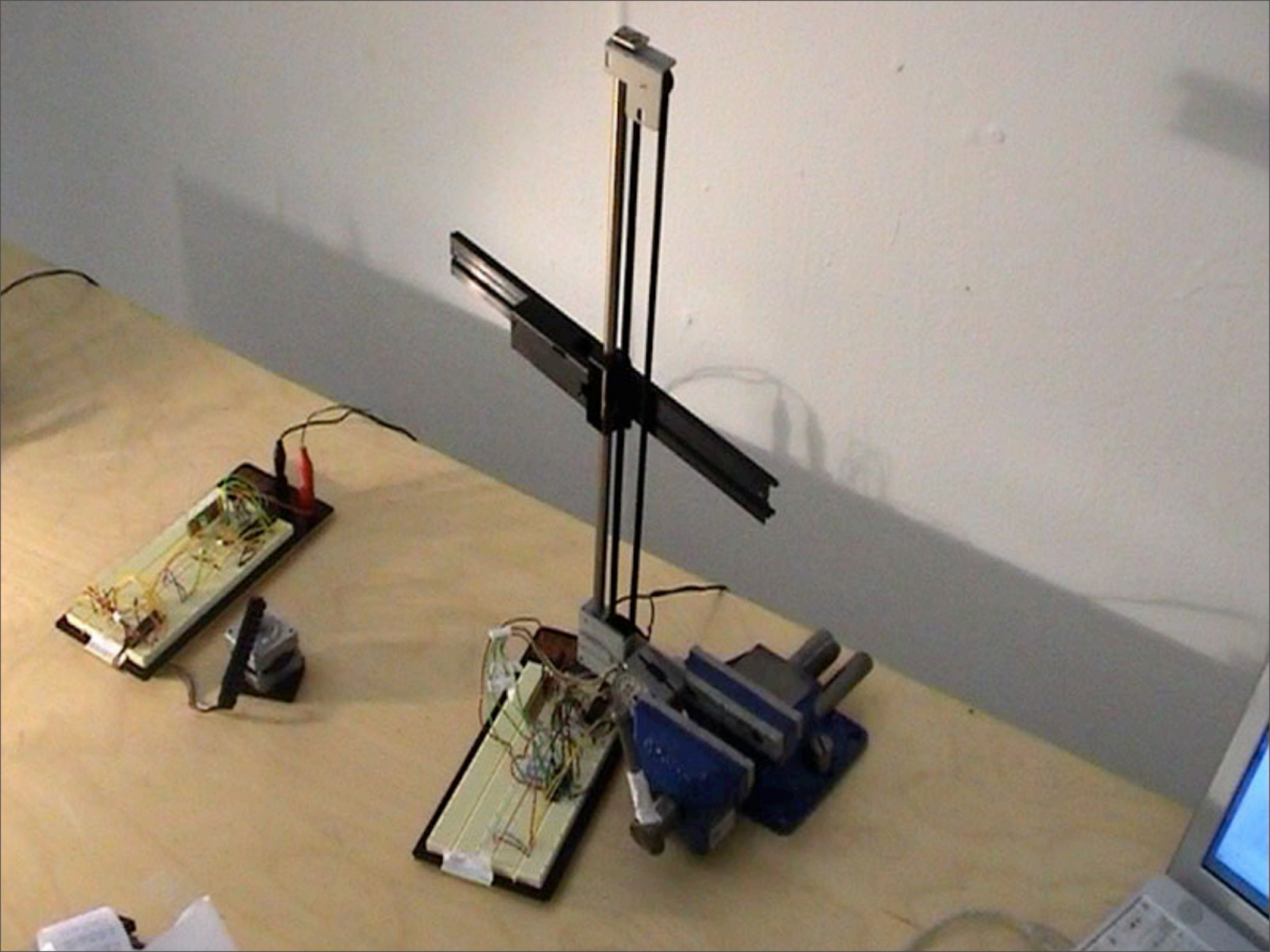

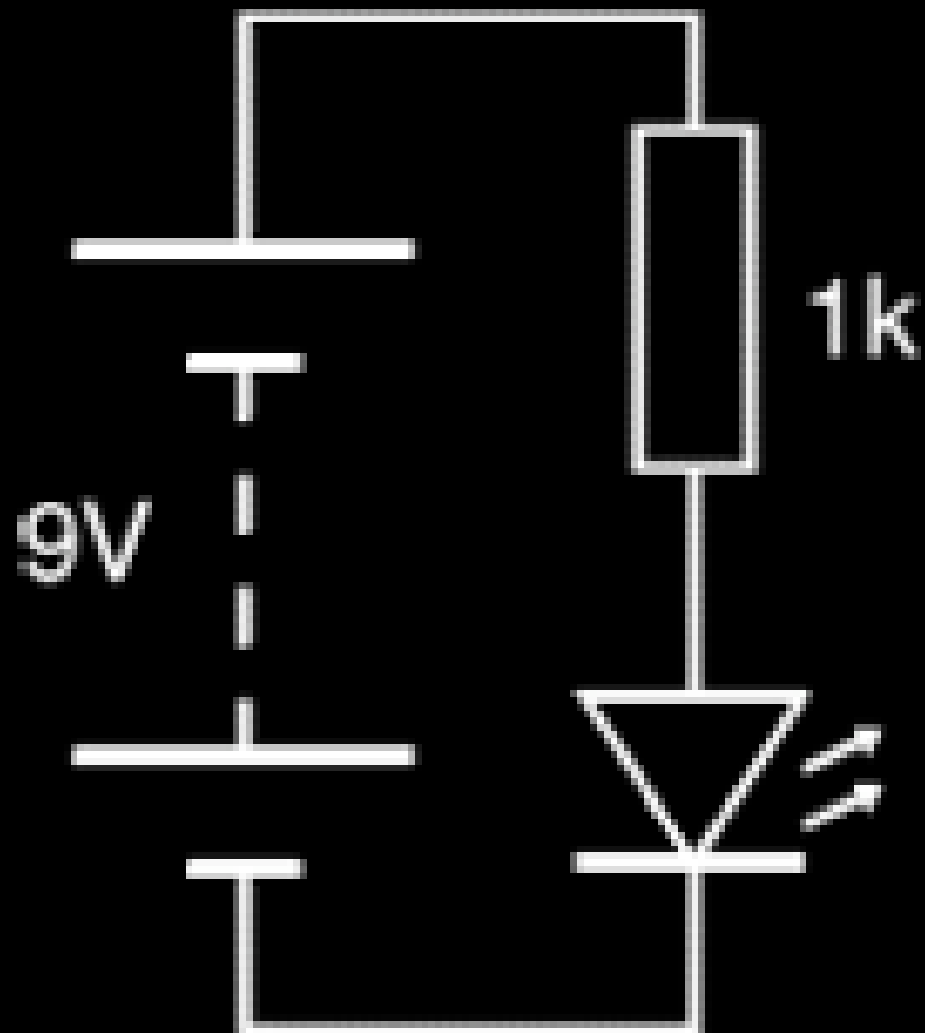

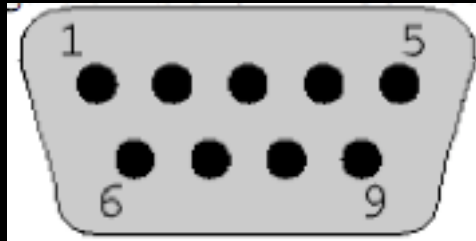

Pins

1	Up	Brown
2	Down	Red
3	Left	Orange
4	Right	Yellow
5	V_{SS} (Power, 5v)	Green
6	Button A / Button B	Blue
7	Multiplexing Select	Purple
8	GND (Ground, 0v)	Grey
9	Start Button / Button C	Black

Switches and Sensors

Switches and sensors allow us to control and use artefacts, to create change or to accomplish tasks. In this workshop we will deconstruct and combine devices, so that our control becomes compromised by the devices own needs and identity.

We will make hybrid objects from an electronic ecology of debris. Please bring:

A 9 volt battery (the small rectangular kind)

Electronic Junk from a charity shop (walkman, alarm clock, joystick, telephone)

recycling // misuse // hybrids // object properties //
electronic farming // feedback systems